

Thermal Print head **TPH 15012.xx**

Two inch Thermal Print Head, 432 dots, 8 dots/mm, serial input

The following parameters are valid for a thermal print head, that means for a ceramic hybrid, mounted on an appropriate cooling plate to guarantee a good thermal contact and to transport the unnecessary heat away from the head.

The mechanical design of the cooling plate, the pin out as well as the operating conditions can be defined together with the customer or modified to satisfy his needs.

Major changes to standard heads or new designs to fit into new applications are welcome to be discussed with the developing engineers of the OECA.

For more detailed information please refer to the complete specification.

Main features

- Number of Heat Elements: 432 dots
- Heat element pitch: 0.125 mm (8 dots/mm)
- Print width: 54 mm
- Average Resistor Value: 800 Ω
- serial interface: 6 MHz
- printing speed: 125 mm/s
- Controlled current ramping: transient and EMI reduction
- anti abrasion coating: TPH 15012.01
- ESD protection: TPH 15012.01

General characteristics

Characteristics	Value	Unit	Note
Print Width	54.00	mm	(2 inch)
Number of Dots	432	dots	
Dot Pitch	0.125	mm	
Dot Density	8	dots/mm	
Dot Resistance	800	Ω	Typical mean value
Dot Resistance Variation	+/- 5	%	Max. variation within head

Maximum ratings

Voltage referenced to V_{SS} terminal. All heating element (dot) ratings are valid only with paper in contact with the heating element.

Symbol	Parameter	min.	max.	Unit
V_{DD}	DC Logic Supply Voltage Range	-0.3	6	V dc
V_{BR}	IC Breakdown Voltage Range		35	V dc
V_I	Input Voltage Range, All Inputs	-0.3	$V_{DD}+0.3$	V dc
I_I	DC Input Current, Any One Input		± 10	mA dc
V_{dot}	DC Driver Transistor Supply Voltage	0	26.4	V dc
P_{dotMAX}	Dot Power		0.88	W/Dot
E_{dotMAX}	Dot Energy		0.7	mJ/Dot
Dc	Duty Cycle (ratio t_{ON} / t_{CYCLE})		60	%
N_{dotMAX}	Number of burning dots at same time per chip		100	%

Electrical operating conditions

Operating conditions at $T_{AMB}=+25^{\circ}C$. For maximum reliability, operating conditions should be selected within the following ranges.

Symbol	Parameter	Conditions	min	max.	Unit
V_{DD}	Logic Supply Voltage Range	-	4.75	5.25	V
V_{dot}	DC Driver Transistor Supply Voltage	-	21.6	26.4	V
f_{CLK}	Maximum Input Clock Frequency	4.75-5.25V	-	6.0	MHz
T_{sub}	Substrate Operating Temperature	4.75-5.25V	-10	+65	$^{\circ}C$

Expected lifetime

When operating according to specified printing conditions the expected lifetime for OECA-Standard Thermal print heads, manufactured all with the same technology and with the same base material, is as follows:

Parameter	Value	Unit	Condition	Note
Strobe pulses	2×10^8			
Mechanical wear	150 100	km km	KL 46 KLS 46 or other OECA approved papers	TPH 15012.01 TPH 15012.00

Mechanical outline (Connector can be modified.)

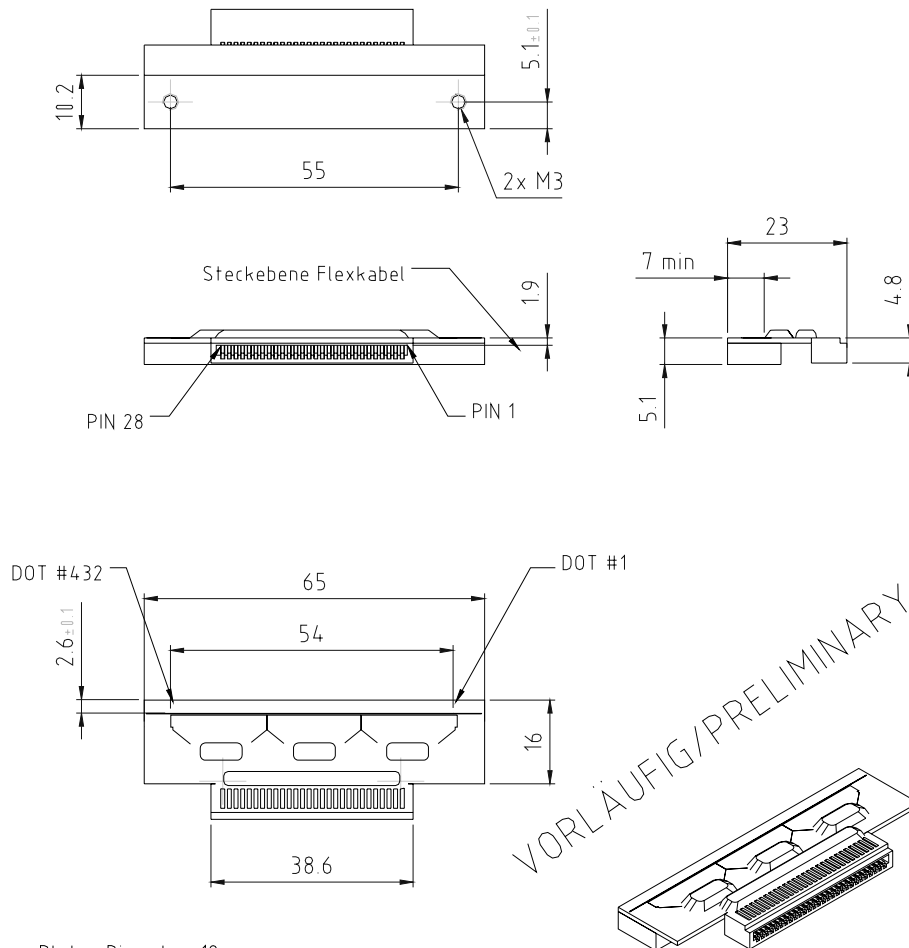

Platen Diameter: 12mm

Connector: JST 28FE-ST-VK-N, modified

Cable for connector: FFC 0.3mm/ 1.25

Please note: Information given in this product information is believed to be accurate and reliable. However no responsibility is assumed for the consequences of its use nor for any infringement of patents or other rights of third parties. No license is granted by implication or otherwise under any patent or patent rights of OECA or HIV GmbH. These products are sold only according to OECA or HIV GmbH's general conditions of sale, unless otherwise confirmed in writing by OECA or HIV GmbH. Product specifications are subject to change without notice.

For further information on technology, delivery terms and conditions and prices please contact your nearest OECA or HIV GmbH office or one of our representatives.

Copyright 2009, OECA Opto-Elektronische Komponenten und Applikations GmbH.
All Rights reserved.