

Thermal Print head **TPH 12182.xx**

Two inch Thermal Printhead, 384 dots, 7.52 dots/mm

The following parameters are valid for a thermal print head, that means for a ceramic hybrid, mounted on an appropriate cooling plate to guarantee a good thermal contact and to transport the unnecessary heat away from the head.

The mechanical design of the cooling plate, the pin out as well as the operating conditions can be defined together with the customer or modified to satisfy his needs.

Major changes to standard heads or new designs to fit into new applications are welcome to be discussed with the developing engineers of the OECA.

For more detailed information please refer to the complete specification.

Main features

- Number of Heat Elements: 384 dots
- Heat element pitch: 0.133 mm (7.52 dots/mm)
- Print width: 51.07 mm
- Average Resistor Value: 750 Ω
- serial interface 4 MHz
- printing speed 100 mm/s
- High power efficiency
- Advanced selectable power control for increased lifetime
- Supplied with heat sink and connector for simple installation
- Controlled current ramping on databus and high current dot supply for transient and EMI-reduction

General characteristics

Characteristics	Value	Unit	Note
Print Width	51.07	mm	
Number of Dots	384	dots	
Dot Pitch	0.133	mm	
Dot Density	7.52	dots/mm	
Dot Dimension	0.133 X 0.133	mm	
Heat Element Resistance (mean value)	625-875	Ω	Typical mean value is 750 Ω
Heat Element Resistance Variation	+/- 15	%	Max. variation within head

Maximum ratings

Voltage referenced to V_{SS} terminal. All heating element (dot) ratings are valid only with paper in contact with the heating element.

Symbol	Parameter	min.	max.	Unit
V_{DD}	DC Logic Supply Voltage Range	-0.5	6	V dc
V_{dot}	DC Driver Transistor Supply Voltage	0	35	V dc
V_{DRV}	DC Driver Control Supply Voltage	-0.5	35	V dc
V_I	Input Voltage Range, All Inputs	-0.5	$V_{DD}+0.5$	V dc
I_I	DC Input Current, Any One Input		± 10	mA dc
E_{dot}	Dot Energy	See below		mJ/dot
P_{dot}	Dot Power	See below		W/dot
T_{stg}	Storage Temperature Range	- 20	+85	°C
T_{AMB}	Ambient Temperature, Operating Environment Humidity	- 10	+55	°C
		10	90	% RH

The maximum dot power and energy graphs are valid at StrobeCycleTime = 1312 μ s = 100 mm/s and substrate temperature < 30°C. Historical control, Adjacent control and Pulse Width Modulation are off.

Electrical operating conditions

Operating conditions at $T_{AMB}=+25^\circ\text{C}$. For maximum reliability, operating conditions should be selected within the following ranges.

Symbol	Parameter	Conditions	min	max.	Unit
V_{DD}	Logic Supply Voltage Range	-	4.75	5.25	V
V_{dot}	DC Driver Transistor Supply Voltage	-	20.12	23.22	V
V_{DRV}	DC Driver Control Supply Voltage		22.0	26.0	V
f_{clk}	Maximum Input Clock Frequency	4.75-5.25	-	4.0	MHz
T_{sub}	Substrate Operating Temperature	4.75-5.25	-10	+85	°C

Mechanical outline

TPH 12182.41

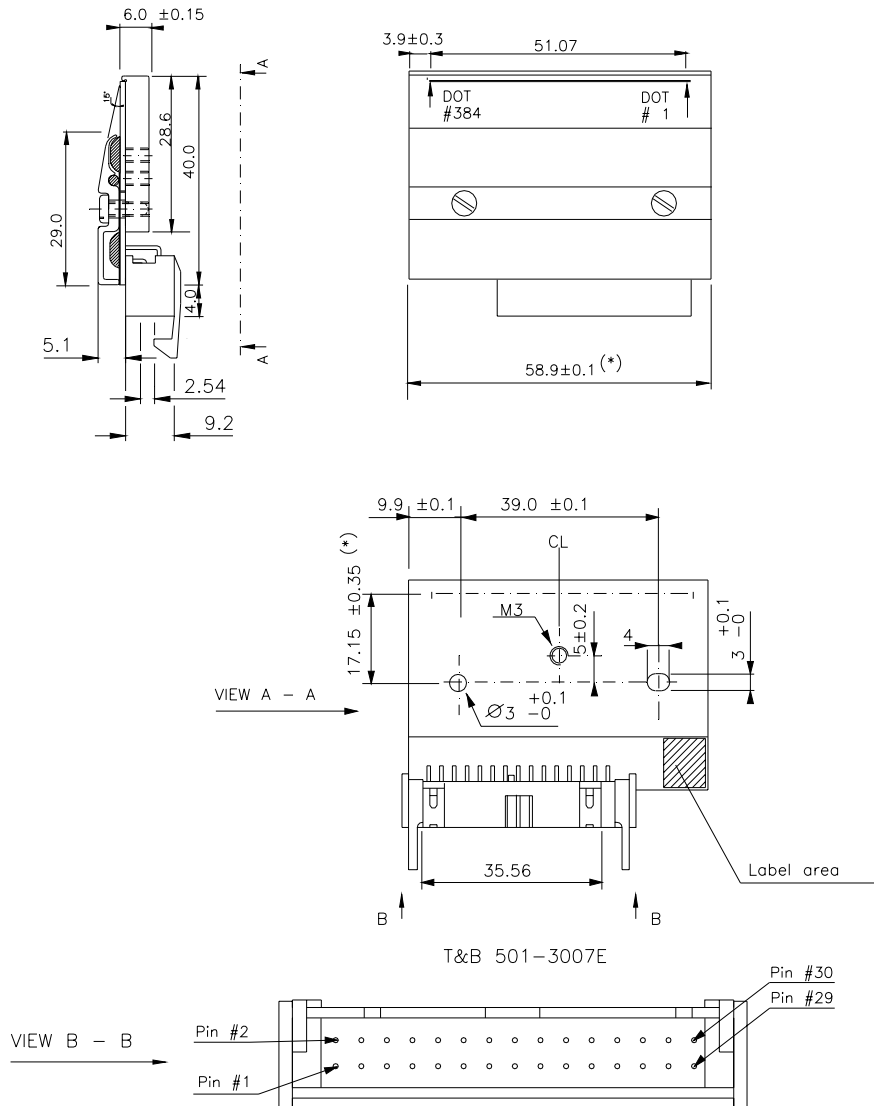

(*) = Critical dimensions

Please note: Information given in this product information is believed to be accurate and reliable. However no responsibility is assumed for the consequences of its use nor for any infringement of patents or other rights of third parties. No license is granted by implication or otherwise under any patent or patent rights of OECA or HIV GmbH. These products are sold only according to OECA or HIV GmbH's general conditions of sale, unless otherwise confirmed in writing by OECA or HIV GmbH. Product specifications are subject to change without notice.

For further information on technology, delivery terms and conditions and prices please contact your nearest OECA or HIV GmbH office or one of our representatives.

Copyright 2009, OECA Opto-Elektronische Komponenten und Applikations GmbH.
All Rights reserved.