

## SSO-AD-500 NIR-TO52-S1 OECA-P302

### Description

The SSO-AD-500 NIR-TO52-S1 OECA-P302 is a Si-APD with a 62.5/125µm pigtail.

### Applications

- Datacom, Ethernet
- General applications

### Features

- 62.5/125/250µm pigtail, length 1.1m



Device can differ from picture.  
For details and pin out please refer to the drawing..

### Absolute Maximum Ratings

( $T_C = 25^\circ\text{C} \pm 2^\circ\text{C}$ )

Parameter	Symbol	min.	max.	Unit
Operating Temperature	$T_{OP} = T_C$	-20	+70	$^\circ\text{C}$
Storage Temperature	$T_{stg}$	-40	+85	$^\circ\text{C}$
Soldering Temperature / Soldering Time <sup>note 1</sup>	$T_{sold} / t_{sold}$		260/10	$^\circ\text{C/s}$

Note 1: Conditions not specified by manufacturer APD.

### Optical and Electrical Characteristics

( $T_C = 25^\circ\text{C} \pm 2^\circ\text{C}$ )

Parameter	Symbol	Condition	min.	typ.	max.	Unit
Breakdown Voltage <sup>note 3</sup>	$V_{BR}$	$I_D = 2\mu\text{A}$	120		300	V
Total Capacitance <sup>note 2</sup>	$C_T$	$M=100$		1.2		pF
Dark Current <sup>note 2</sup>	$I_D$	$M=100$		0.5	5	nA
Gain	M		200			
Optimum Gain	M			50-60		
Rise Time	$t_R$			550		ps
Spectral Responsivity <sup>note 3</sup>	R	$\lambda = 780 \text{ nm}$	0.55			A/W
Cut Off Frequency	$f_C$			400		MHz
Noise Equivalent Power	NEP	$M=100$ $\lambda = 880 \text{ nm}$		$2 \cdot 10^{-14}$		$(\text{W/Hz})^{1/2}$

Note 2:

Measurement Conditions

Setup of photo current 10nA at  $M=1$  and irradiation by a NIR-LED (880nm, 80nm bandwidth).

Rise of the photo current up to 1µA, ( $M=100$ ) by internal multiplication due to an increasing bias voltage.

Note 3: Each device is delivered with individually responsivity and breakdown voltage.

## Drawing

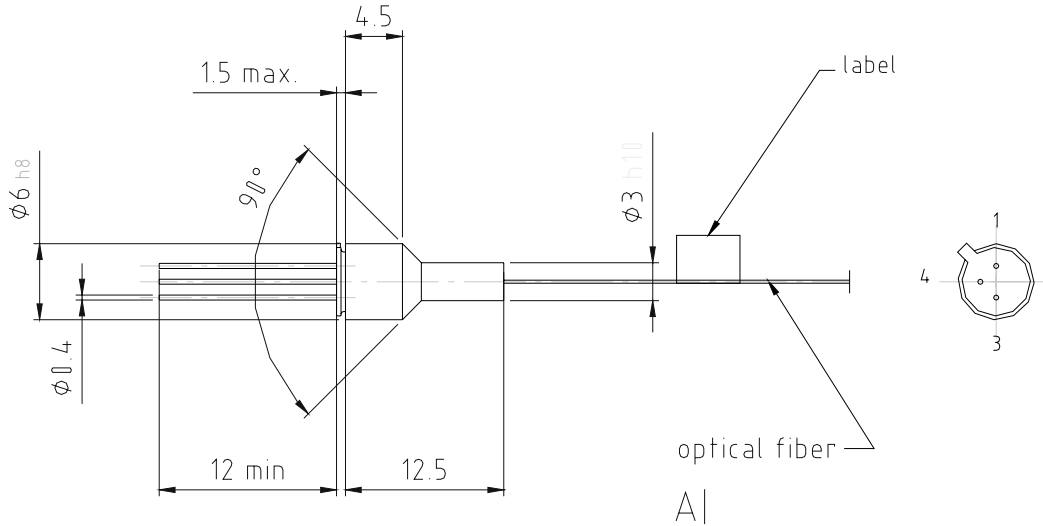

A - Optical fiber acc. to specification  
typical length 1,1 m

Pinout acc. to specification  
tolerances acc. to DIN ISO 2768-mH  
all dimensions in mm

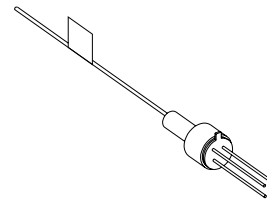

### Pin-Out

Pin	SSO-AD500 NIR-TO52-S1
1	Cathode
2	-
3	Anode
4	Case

**Please note:** Information given in this product information is believed to be accurate and reliable. However no responsibility is assumed for the consequences of its use nor for any infringement of patents or other rights of third parties. No license is granted by implication or otherwise under any patent or patent rights of OECA or HIV GmbH. These products are sold only according to OECA or HIV GmbH's general conditions of sale, unless otherwise confirmed in writing by OECA or HIV GmbH. Product specifications are subject to change without notice.

For further information on technology, delivery terms and conditions and prices please contact your nearest OECA or HIV GmbH office or one of our representatives.

Copyright 2009, OECA Opto-Elektronische Komponenten und Applikations GmbH.  
All Rights reserved.