

## 85D62K4

## PIN/Preamp 62kHz 650nm / 850nm

### Description

This optical detector consists of a high sensitive Si-PIN photodiode and a low noise transimpedance amplifier (TIA). It is designed for detection from DC up to 62kHz. The preamplifier's linearity and low thermal drift makes it ideal for various applications.

### Features

- Analogue amplified voltage output
- Low thermal drift
- High interference rejection

### Applications

- Process Monitoring
- Environmental Monitoring
- General Industries



Device can differ from picture.  
For details and pin out please refer to the drawing.

### Absolute Maximum Ratings

Parameter	Symbol	min.	max.	Unit
DC Supply Voltage (between $V_{CC+}$ -terminals and $V_{CC-}$ -terminals)	$V_{CC+}-V_{CC-}$	-0.3	36	V
Operating Temperature	$T_{OP} = T_C$	-20	+80	°C
Storage Temperature	$T_{stg}$	-30	+100	°C
Soldering Temperature / Soldering Time	$T_{sold}/t_{sold}$		260/10	°C/s

### Recommended Operating Conditions

Parameter	Symbol	min.	max.	Unit
DC Supply Voltage (between $V_{CC+}$ -terminals and $V_{CC-}$ -terminals)	$V_{CC+}-V_{CC-}$	7	36	V

## Optical and Electrical Characteristics

$V_{CC+}=+15V, V_{CC-}=-15V, T_C=25^{\circ}C \pm 2^{\circ}C$

Parameter	Symbol	Condition	min.	typ.	max.	Unit
Supply Current	$I_{CC}$		-	4	6	mA
Power Dissipation	PD		-	120	180	mW
Dark Level Noise (RMS)	$N_{DARK}$		-	1.5	-	mV
Output Offset (MAX)	$V_{OFF}$		-7	-	+7	mV
Irradiance Responsivity	$R_E$	$E = 10nW/mm^2$ $\lambda = 850nm$	100	230	-	$V/(\mu W/mm^2)$
Frequency Response (-3dB)	$f_{-3dB}$		-	62	-	kHz
Output Current (Sink/Source)	$I_{IN}/I_{OUT}$		-	-	1/10	mA
Step Response (Rise/Fall)	$t_r/t_f$		-	8.0	-	$\mu s$
Saturation	$V_{SAT+}$ $V_{SAT-}$		-	-	+12 -14	V
Numerical Aperture	NA		-	0.17	-	-

Incident irradiance increases  $V_{OUT}$

## Functional Schematic / Typical Application Circuit

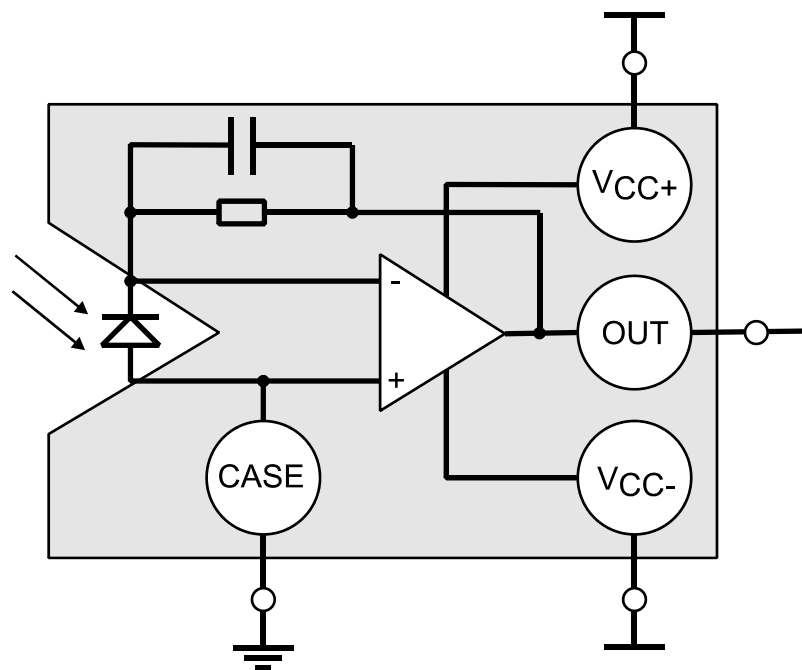

## Drawing

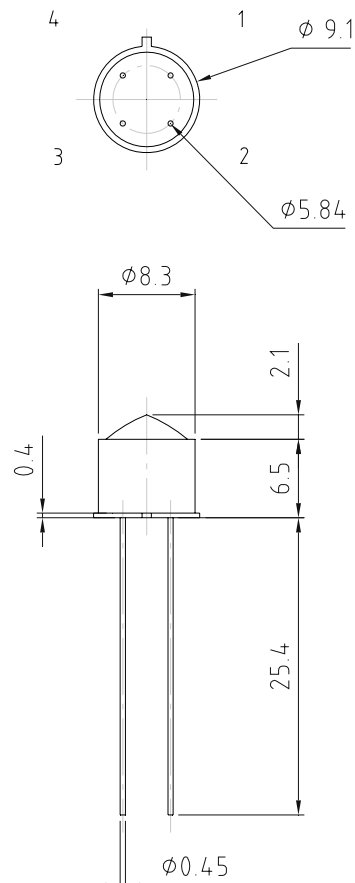

Pinout acc. to specification  
pins solderable acc. to specification  
all dimensions in mm

### Pin out

Pin	85D62K4
1	Case
2	OUT
3	V <sub>CC+</sub>
4	V <sub>CC-</sub>

**Please note:** Information given in this product information is believed to be accurate and reliable. However no responsibility is assumed for the consequences of its use nor for any infringement of patents or other rights of third parties. No license is granted by implication or otherwise under any patent or patent rights of OECA or HIV GmbH. These products are sold only according to OECA or HIV GmbH's general conditions of sale, unless otherwise confirmed in writing by OECA or HIV GmbH. Product specifications are subject to change without notice.

For further information on technology, delivery terms and conditions and prices please contact your nearest OECA or HIV GmbH office or one of our representatives.

Copyright 2009, OECA Opto-Elektronische Komponenten und Applikations GmbH. All Rights reserved.